

# Rigenerazione e innovazione per un abitare sostenibile

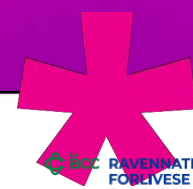

Maria Cristina Garavelli  
Officina Meme Architetti



# #RIGENERAZIONE

> OPPORTUNITA' PER

- > riflettere sull'abitare e sul valore della fragilità
- > invertire la rotta e recuperare i luoghi abbandonati
- > trasformare la dismissione in oasi di verde e benessere in ottica di **SOSTENIBILITA' GLOBALE**

**CONSUMO DI SUOLO A SALDO ZERO**



# #RIGENERAZIONE

## > INNOVAZIONE

> introduce nuove modalità di progettazione  
per la trasformazione del territorio  
per incrementare il benessere e la qualità della vita  
per rispondere alle esigenze delle persone  
che sono al centro del "mondo dell'abitare".

PLEASE  
DON'T  
LEAVE ME

# #RAVENNA DARSENA

> trasformazione  
e valorizzazione attraverso  
il recupero del valore testimoniale e  
identitario in ottica di  
innovazione e sostenibilità

*centro  
storico  
193 ha*

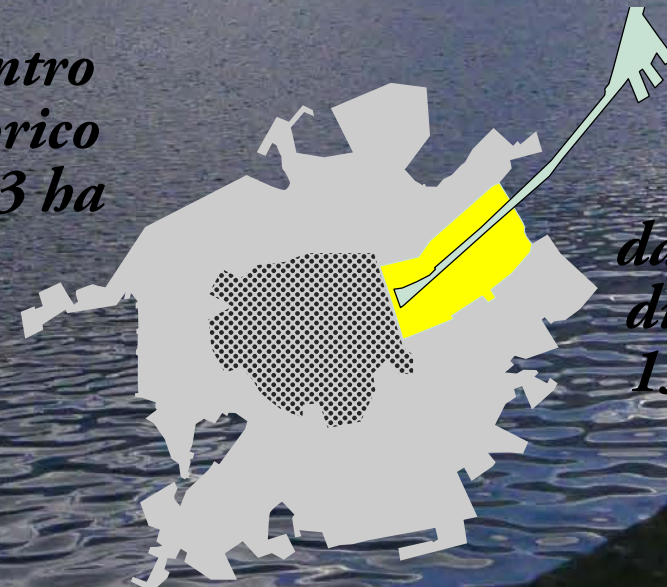

*darsena  
di città  
136 ha*

# #PROCESSO DI RIGENERAZIONE

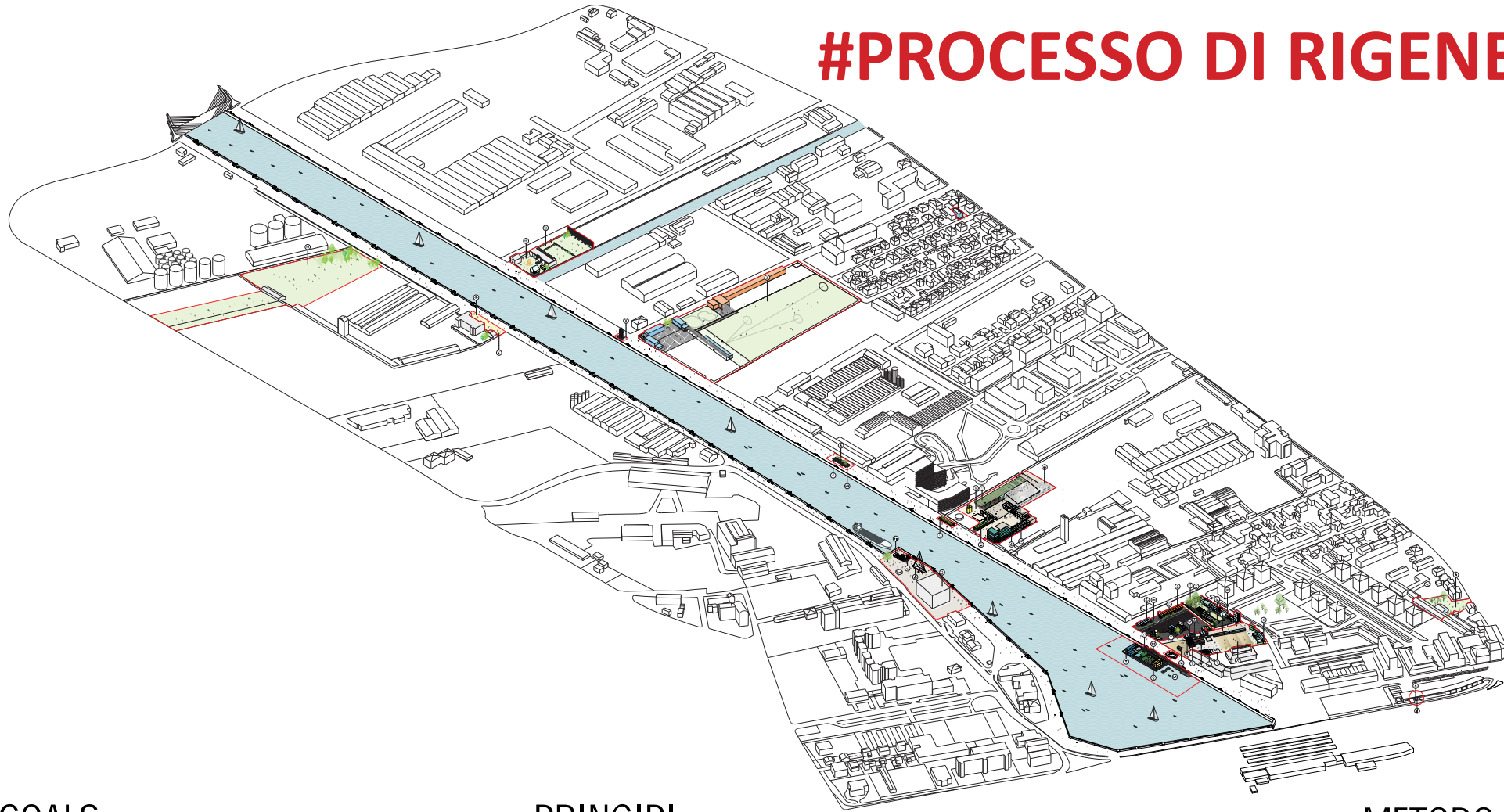

## GOALS



riqualificazione  
della Darsena



nuovi servizi  
per la comunità



connessione  
urbana

## PRINCIPI



temporaneità e  
reversibilità



socialità



sostenibilità



innovazione

## METODO



processo  
incrementale

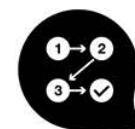

**METODO  
REPLICABILE**

# #METODO DI LAVORO

- > ascolto empatico di chi vive nei luoghi da rigenerare per mettere in evidenza **BISOGNI** e costruire **RELAZIONI**, finalizzate al coinvolgimento attivo dei cittadini nel processo di trasformazione e gestione degli spazi
- > analisi del contesto urbano, ambientale, socio-economico, per individuare criticità e potenzialità e quindi la giusta strategia per raggiungere i risultati attesi dalla comunità
- > **USO TEMPORANEO** come strategia innovativa e sostenibile di innesco e trasformazione degli ambiti dismessi e complessi, consente il giusto equilibrio economico a breve e medio termine, e accompagna un luogo dallo stato di abbandono alla sua trasformazione definitiva.

> metodo  
replicabile

processo  
incrementale

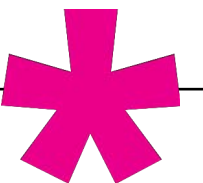

# 2014#OFF GRID CAFE prototipo temporaneo



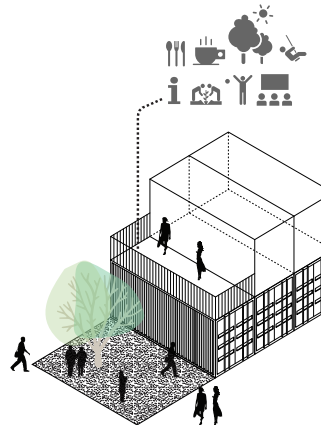
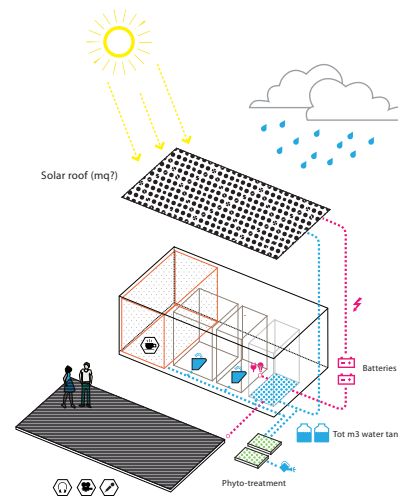
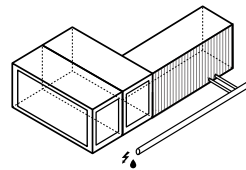
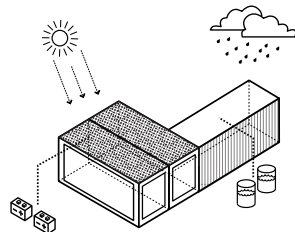
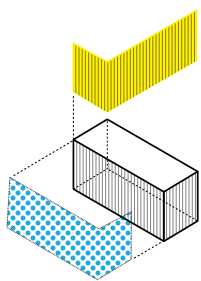
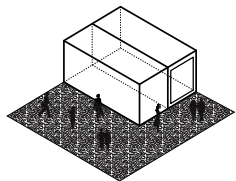
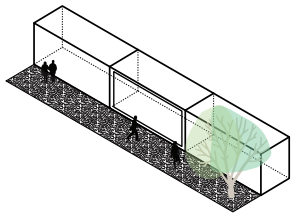
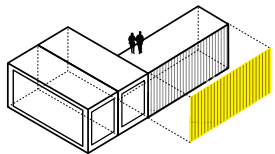
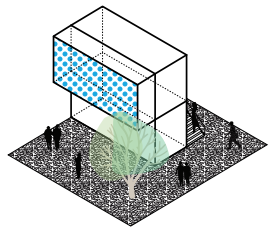
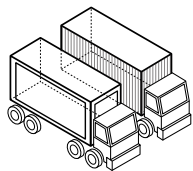
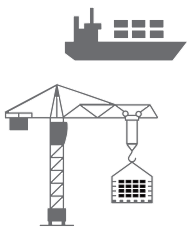
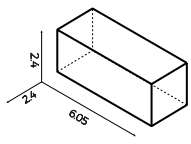
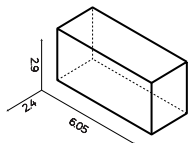
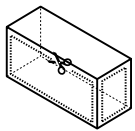
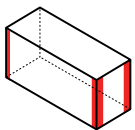
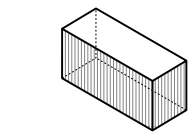

SUSTAINABLE DEVELOPMENT



INNOVATION RESEARCH



PROJECT QUALITY



POSITIVE SOCIAL IMPACT

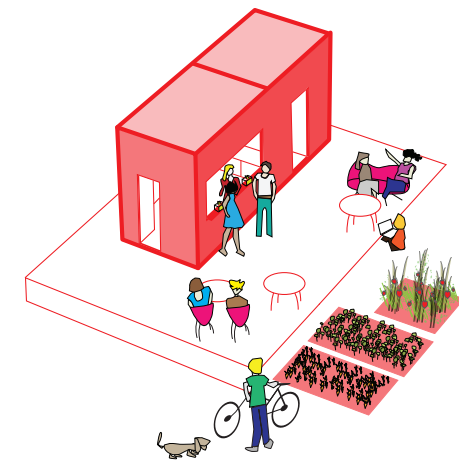

01



la struttura

La struttura del box container è in legno xlam e predisposta con base a telaio metallico per l'assemblaggio

02



il trasporto

Mutabox è realizzato con le dimensioni standard del container marittimo e può essere trasportato in modo efficiente da un mezzo ad un altro (nave, camion...)

03



l'assemblaggio

Mutabox può essere utilizzato accoppiato, in linea o su più livelli per realizzare maggiori volumi o differenti soluzioni tipologiche

04



la customizzazione

Mutabox è disponibile con diversi rivestimenti e predisposto per l'allaccio alle utenze o nella versione off-grid in funzione dell'utilizzo



meno più

consumo di suolo e di energia

felicità interna lorda





# 2015#MUTABOX

> innesco  
ambiti dismessi  
off-grid



**2015>2016 #DARSENA POP UP**



**PROCESSO DI RIGENERAZIONE**  
UNA STRATEGIA CONTRO IL  
CONSUMO DI SUOLO (>>0)



VALORIZZAZIONE DELL'**IDENTITA'**  
E DEL PATRIMONIO **PORTUALE**



ATTIVAZIONE PER FASI  
E CON UNO SVILUPPO  
**REVERSIBILE**



SVILUPPO DI **CONNESSIONE** TRA LA  
CITTA' E LA BANCHINA



DARSENA POP UP COME **HUB**  
DI AGGREGAZIONE E **SOCIALITA'**



> socialità  
> innovazione  
> sostenibilità



+25000 mq  
+ 11 spazi  
+20 attività

> innesco  
per la trasformazione  
di aree adiacenti

> la creazione di un metodo efficace per la rigenerazione di ambiti complessi ha permesso di ampliare e sviluppare nuove progettualità interessando ambiti di ricerca a livello europeo

# #TEMPUS PROGETTO PILOTA

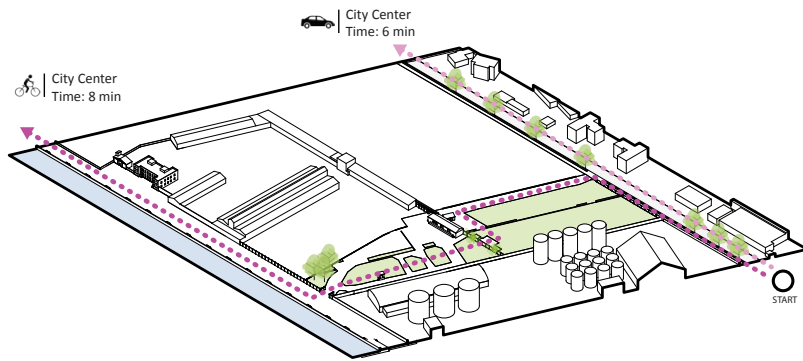

+ MOBILITA' SOSTENIBILE

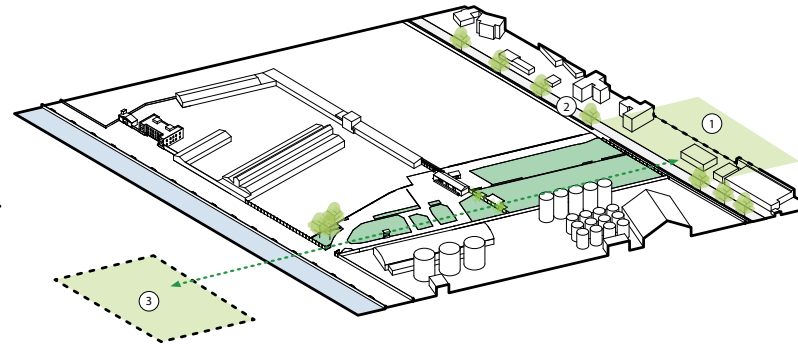

+ RI-CONNESSIONE VERDE

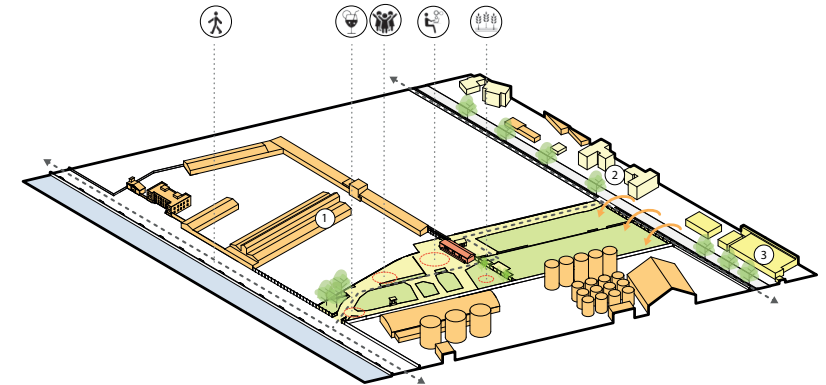

+ SERVIZI AL QUARTIERE

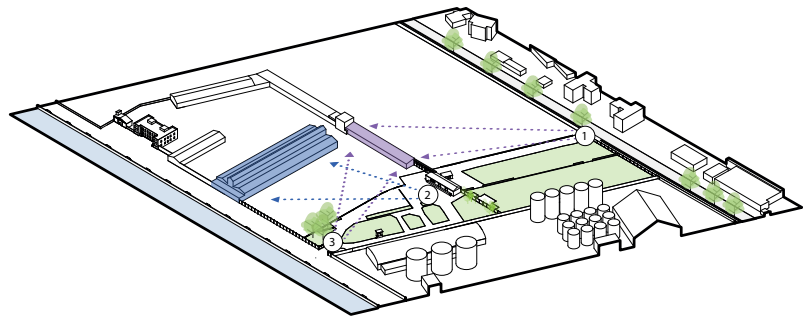

+ VISUALI SUL PATRIMONIO PORTUALE

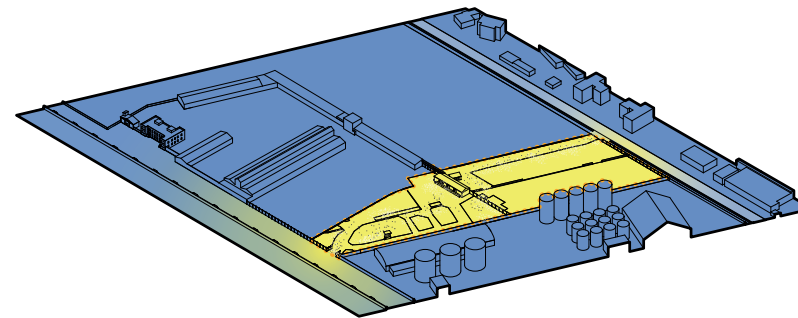

+ PRESIDIO DELL'AREA

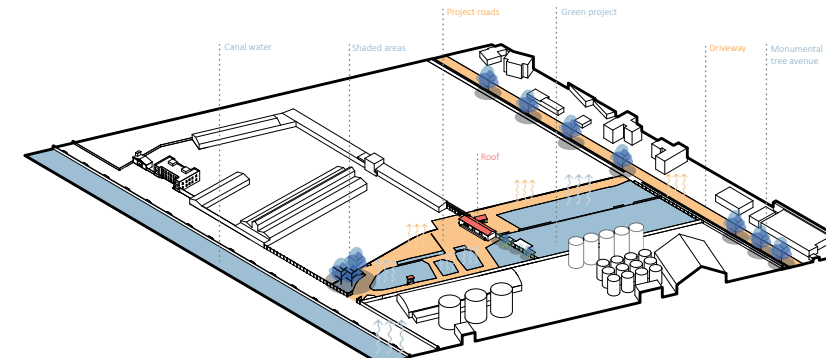

+ PERMEABILITA' DEL SUOLO

# TIMELINE

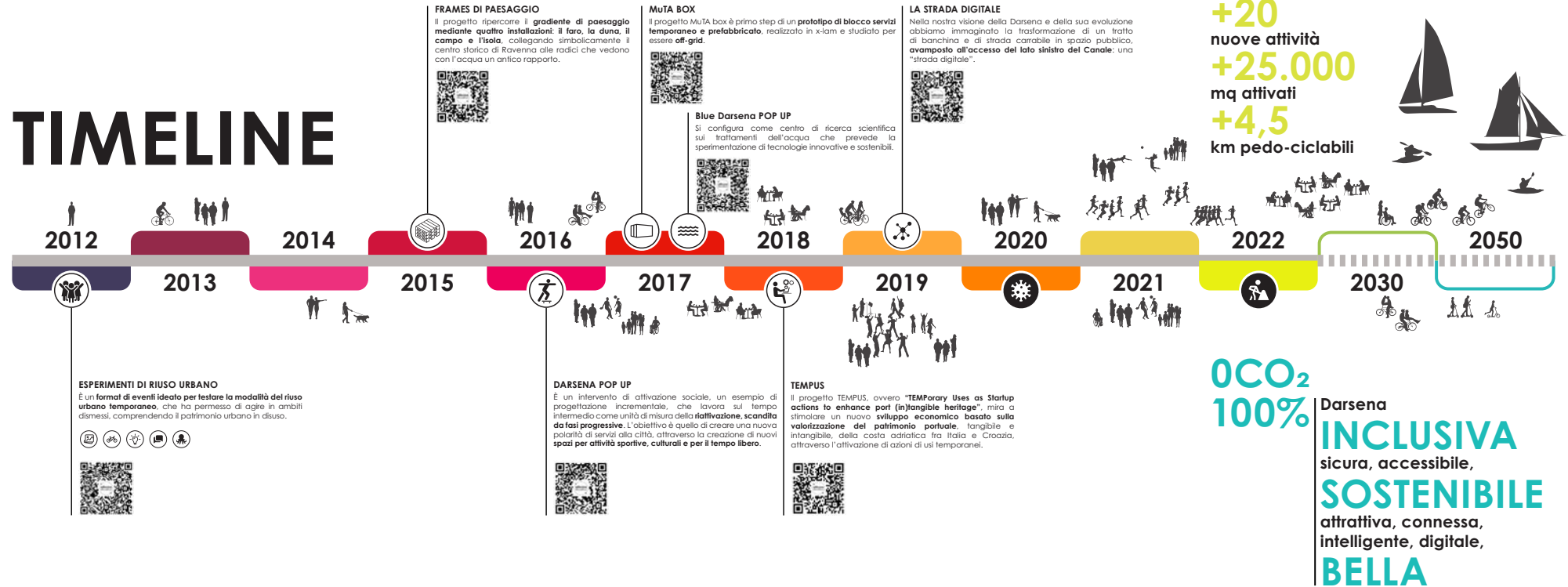

> la temporaneità come strumento innovativo è veloce e allineato ai bisogni della comunità

> la rigenerazione innovativa innesca il cambiamento e genera un incremento di valore territoriale e sociale che in **ottica circolare parte e torna alla comunità** e che mira a migliorare la qualità e il benessere PER TUTTI.

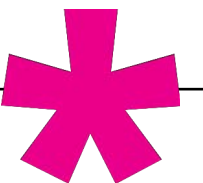



> innovazione e qualità per tutti



# Value chain RIGENERA

## Il contributo tecnologico risulta determinante per:

- > **strumentare un processo circolare**, destinato a essere ripetuto più volte con l'obiettivo di riverberare gli effetti virtuosi della rigenerazione, che in tal modo diventa principio guida del progetto sostenibile.
- > facilitare la raccolta dei dati materiali (lo stato di fatto e di diritto degli spazi investiti dal processo rigenerativo), delle informazioni veicolate dai cittadini (attraverso trasformazione degli spazi stessi), la loro elaborazione e condivisione (la costruzione del quadro conoscitivo sviluppato dai progettisti), la comunicazione (in cui emerge il ruolo dell'Amministrazione) e la valutazione d'impatto (misurazione degli effetti) a favore dell'intera comunità investita dal progetto.
- > sviluppare modelli collaborativi supportando la creazione di comunità intelligenti, rispettose delle specificità locali e dell'ambiente, connesse, votate a mobilità e logistica green e intermodale, aperte alla città e al mondo.

**CLUST-ER  
BUILD**  
EDILIZIA E COSTRUZIONI

>PPP

comunità  
intelligenti  
rispettose  
connesse  
mobilità green  
aperte alla città  
e al mondo

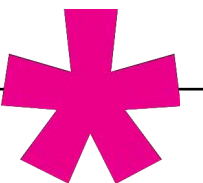



CAMBIAMENTO >  
nuovo valore basato  
sulle relazioni  
per una comunità intelligente  
digitale e resistente

# after\*

FUTURI DIGITALI



M. info@officinameme.com  
www.officinameme.com

# grazie!



Comune di  
Massa Lombarda

